

CHALLENGER

MS: 200

ASSEMBLY MANUAL



ALMOST READY TO FLY

Specifications

Wingspan-----	52.8 in-----	134cm.
Wing area-----	542.5 sq.in-----	35 sq.dm.
Approximate flying weight-----	5.1-6.0lbs-----	2.3-2.7kg.
Length-----	45.7 in-----	116cm.
Recommended engine size-----	.46-.55 cu.in-----	2-stroke.
	.52-.62cu.in-----	4-stroke.

Radio System required 4 channels with 5 servos.

Electric conversion : optional.

Made in Vietnam.

FACTORY BUILT MODEL

INTRODUCTION.

Thank you for choosing the **CHALLENGER** ARTF by SEAGULL MODELS. The **CHALLENGER** was designed with the intermediate/advanced sport flyer in mind. It is a scale airplane which is easy to fly and quick to assemble. The airframe is conventionally built using balsa, plywood to make it stronger than the average ARTF, yet the design allows the aeroplane to be kept light. You will find that most of the work has been done for you already. The motor mount has been fitted and the hinges are pre-installed. Flying the **CHALLENGER** is simply a joy.

This instruction manual is designed to help you build a great flying aeroplane. Please read this manual thoroughly before starting assembly of your **CHALLENGER**. Use the parts listing below to identify all parts.

WARNING.

Please be aware that this aeroplane is not a toy and if assembled or used incorrectly it is capable of causing injury to people or property. WHEN YOU FLY THIS AEROPLANE YOU ASSUME ALL RISK & RESPONSIBILITY.

If you are inexperienced with basic R/C flight we strongly recommend you contact your R/C supplier and join your local R/C Model Flying Club. R/C Model Flying Clubs offer a variety of training procedures designed to help the new pilot on his way to successful R/C flight. They will also be able to advise on any insurance and safety regulations that may apply.

ADDITIONAL ITEMS REQUIRED.

- .46-.55 2-stroke engine
- .52-.62 4-stroke engine
- Computer radio with six servos
- Glow plug to suit engine
- Propeller to suit engine
- Protective foam rubber for radio system
- Silicone fuel line

TOOLS & SUPPLIES NEEDED.

- Thick cyanoacrylate glue
- 30 minute epoxy
- 5 minute epoxy
- Hand or electric drill
- Assorted drill bits
- Modelling knife
- Straight edge ruler
- 2mm ball driver
- Phillips head screwdriver
- 220 grit sandpaper
- 90° square or builder's triangle
- Wire cutters
- Masking tape & T-pins
- Thread-lock
- Paper towels

PARTS LISTING.**FUSELAGE ASSEMBLY**

- (1) Fuselage
- (1) Canopy hatch

WING ASSEMBLY

- (1) Right wing half/ aileron
- (1) Left wing half with/ aileron
- (1) Aluminium dihedral brace

Tail section assembly

- (1) Horizontal stabilizer/ elevator halves.
- (1) Rudder halves.

Some more parts.

HARDWARE PACK**COWLING**

Landing gear.....

FUEL TANK INSTALLATION.

Please see below pictures

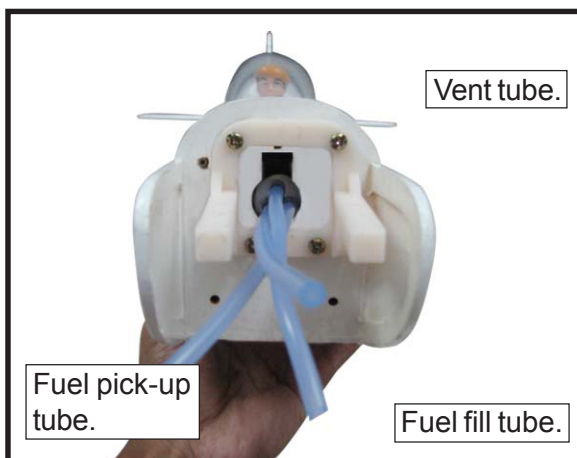
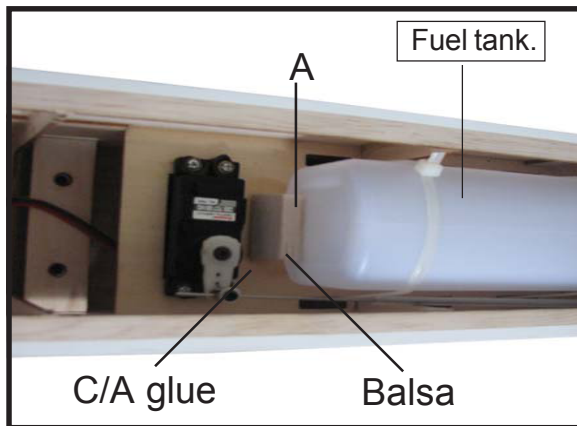
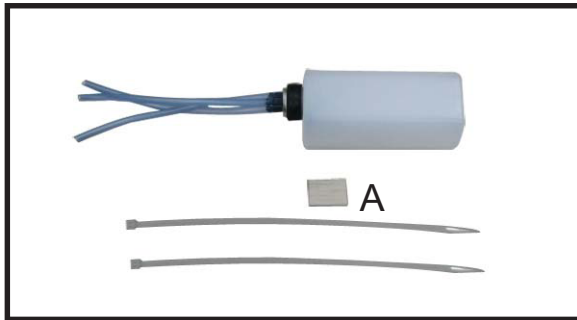

 **Blow through one of the lines to ensure the fuel lines have not become kinked inside the fuel tank compartment. Air should flow through easily.**

ENGINE MOUNT INSTALLATION.

1) Position the engine with the drive washer (110mm) forward of the firewall as shown.

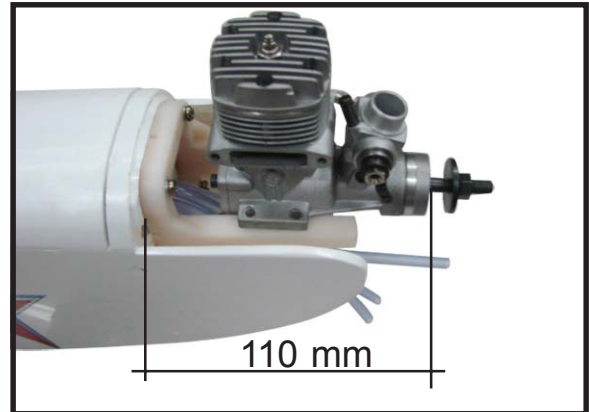

2) Use a pin drill and 2mm drill bit to drill a small indentation in the mount for the engine mounting screw..

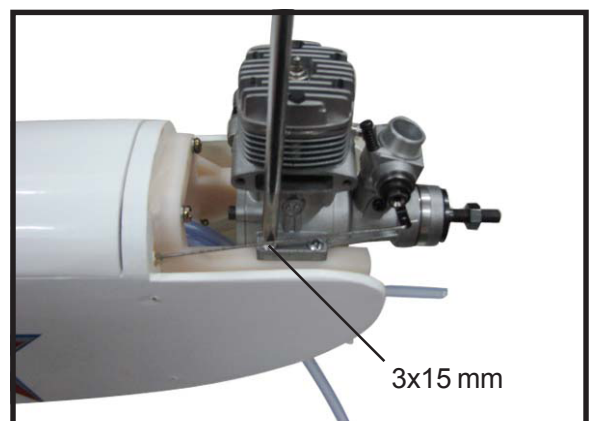
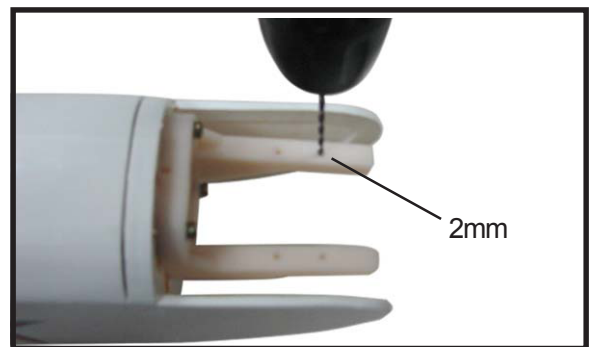
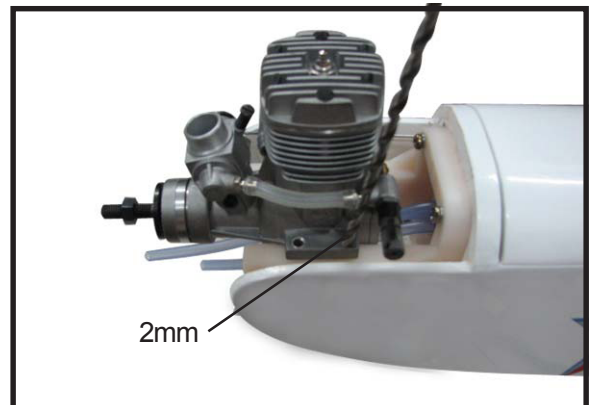

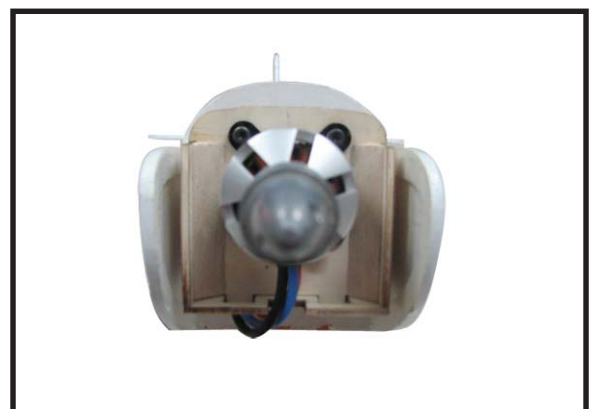
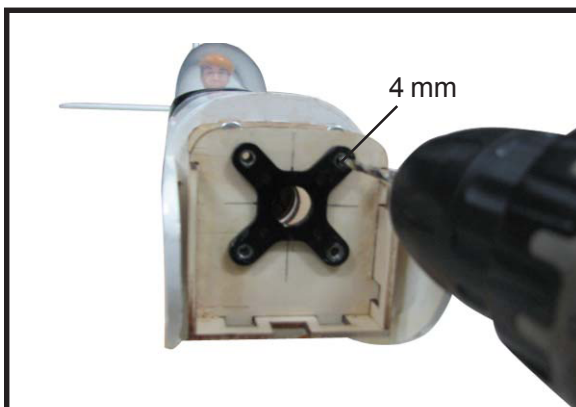
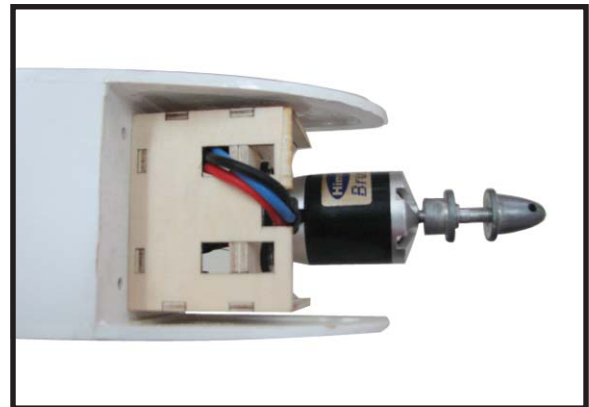
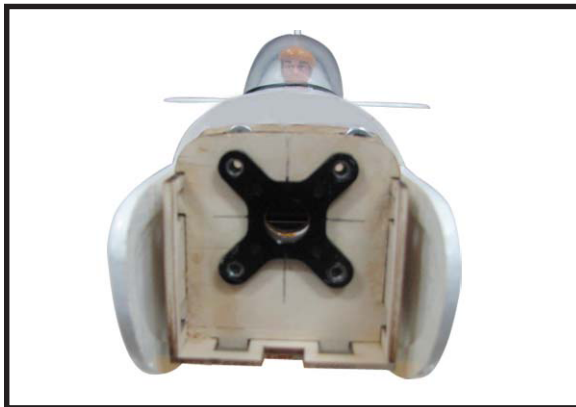
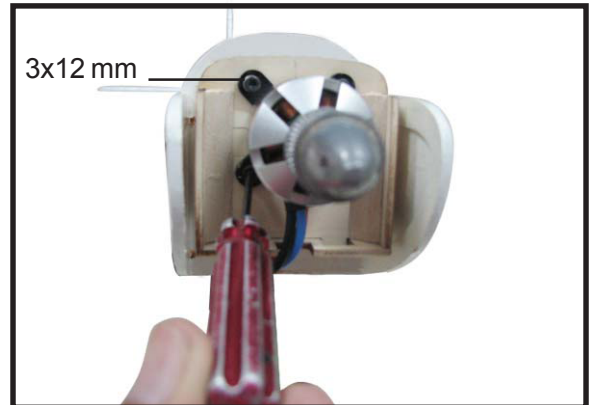
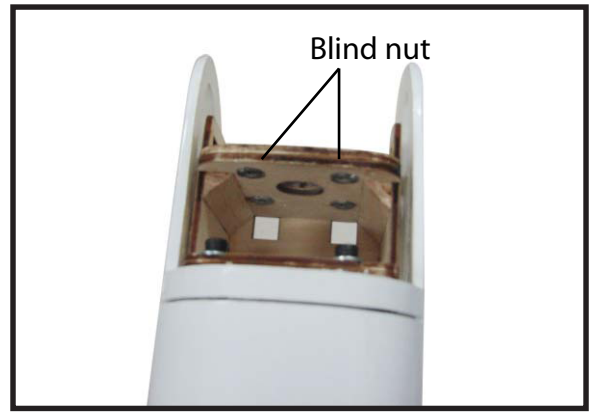
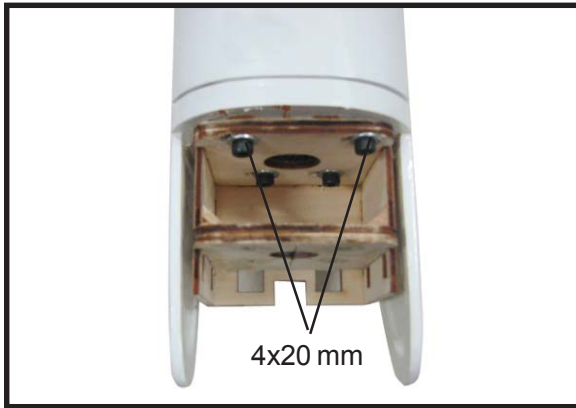

4) Attach the motor to the front of the electric motor box using 4mm blind nut, four M3x15mm hex head bolts to secure the motor. Please see picture as shown.

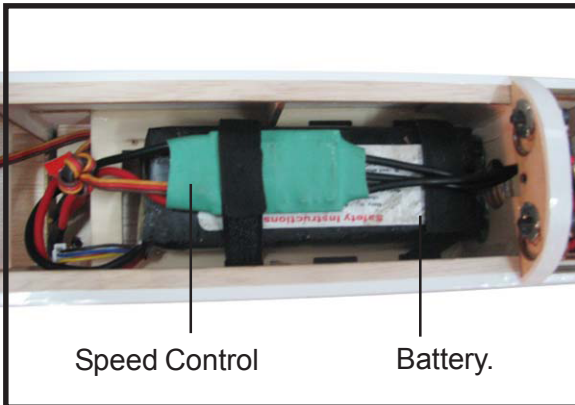
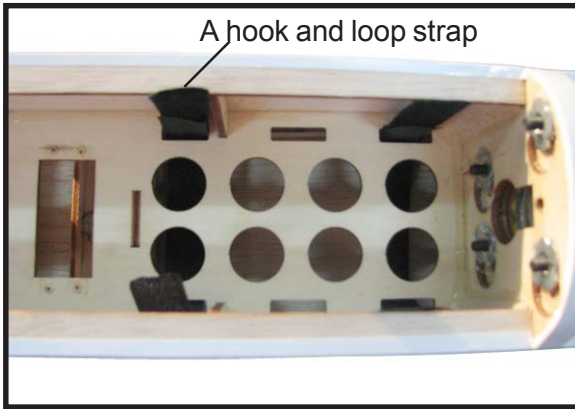

COWLING INSTALLATION.

□ 1) Slide the fiberglass cowl over the engine and line up the back edge of the cowl with the marks you made on the fuselage then trim and cut.



□ 2) While keeping the back edge of the cowl flush with the marks, align the front of the cowl with the crankshaft of the engine. The front of the cowl should be positioned so the crankshaft is in **nearly** the middle of the cowl opening. Use the spinner backplate as a guide. Hold the cowl firmly in place using pieces of masking tape.



□ 3) Install the muffler and muffler extension onto the engine and make the cut out in the cowl for muffler clearance. Connect the fuel and pressure lines to the carburetor, muffler and fuel filler valve. Secure the cowl to fuselage using the 3x10mm screws (4).

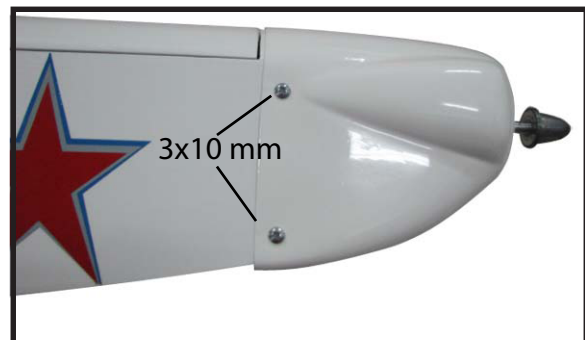



INSTALLING THE SPINNER.

Install the spinner backplate, propeller and spinner cone.

 *The propeller should not touch any part of the spinner cone. If it does, use a sharp modeling knife and carefully trim away the spinner cone where the propeller comes in contact with it.*



INSTALLING THE FUSELAGE SERVO.

 *Because the size of servos differ, you may need to adjust the size of the precut opening in the mount. The notch in the sides of the mount allow the servo lead to pass through.*

- 2) Install the rubber grommets and brass collets onto the throttle servo. Test fit the servo into the aileron servo mount.
- 3) Secure the servos with the screws provided with your radio system.

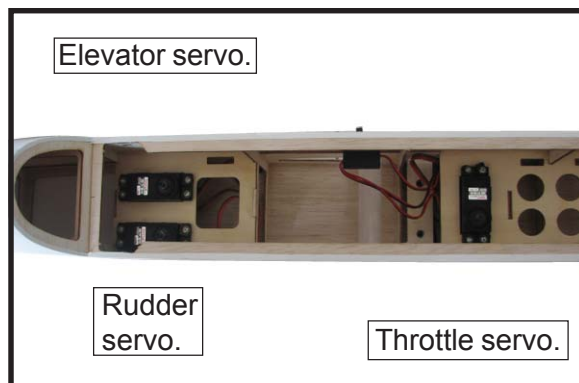

INSTALLING THE SWITCH.

Install the switch into the precut hole in the side, in the fuselage.

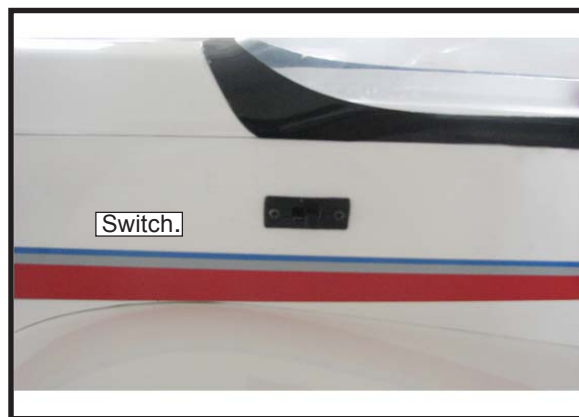

THROTTLE SERVO ARM INSTALLATION.

□ 1) Install adjustable servo connector in the servo arm as same as picture below:

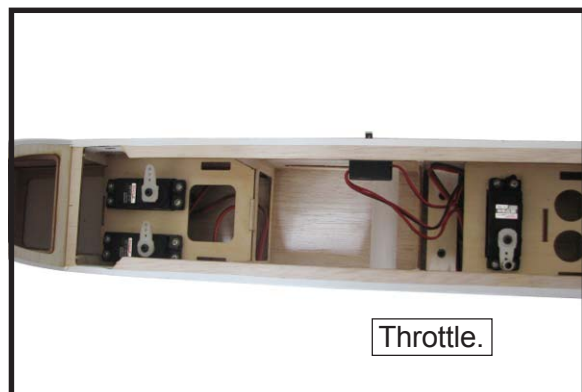
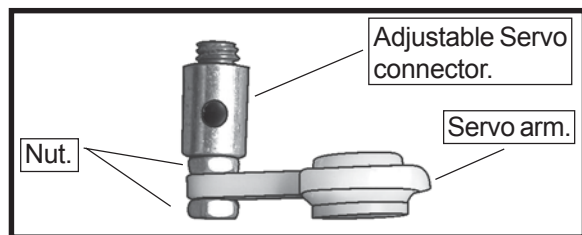

HORIZONTAL STABILIZER.

□ When you are sure that everything is aligned correctly, mix up a generous amount of 30 Minute Epoxy. Apply a thin layer to the top and bottom of the stabilizer mounting area and to the stabilizer mounting platform sides in the fuselage. Slide the stabilizer in place and realign. Double check all of your measurements once more before the epoxy cures. Hold the stabilizer in place with T-pins or masking tape and remove any excess epoxy using a paper towel and rubbing alcohol.

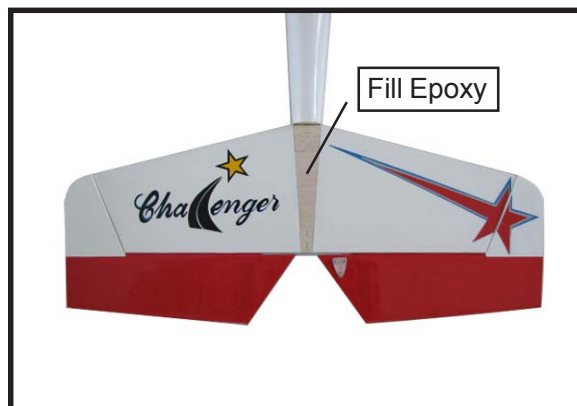
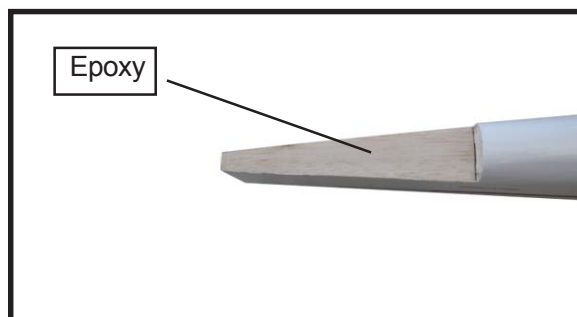
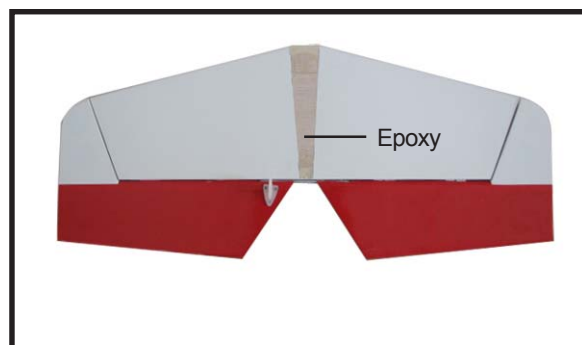

VERTICAL STABILIZER INSTALLATION.



□ 1) Using a modeling knife, remove the covering from over the precut hinge slot cut into the lower rear portion of the fuselage.

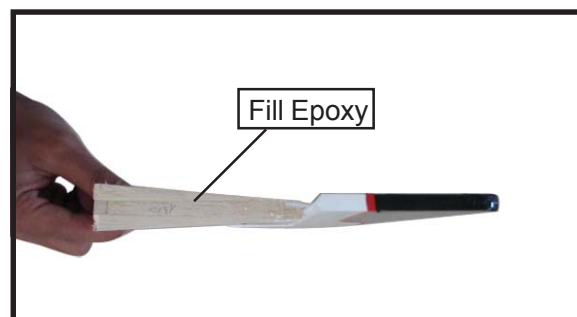

□ 2) While holding the vertical stabilizer firmly in place, use a pen and draw a line on each side of the vertical stabilizer where it meets the top of the fuselage.



□ 3) Slide the vertical stabilizer back in place. Using a triangle, check to ensure that the vertical stabilizer is aligned 90° to the horizontal stabilizer.

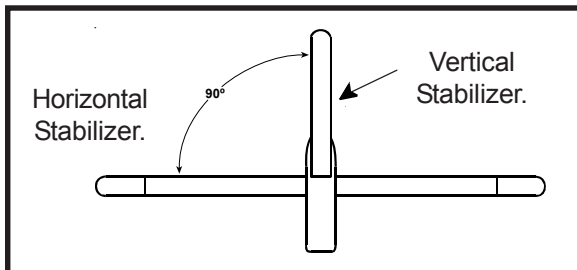

□ 4) When you are sure that everything is aligned correctly, mix up a generous amount of 30 Minute Epoxy. Apply a thin layer to the mounting slot in the top of the fuselage and to the sides and bottom of the vertical stabilizer mounting area. Apply epoxy to the bottom and top edges of the filler block and to the lower hinge also.

Set the stabilizer in place and realign. Double check all of your measurements once more before the epoxy cures. Hold the stabilizer in place with T-pins or masking tape and remove any excess epoxy using a paper towel and rubbing alcohol. Allow the epoxy to fully cure before proceeding.

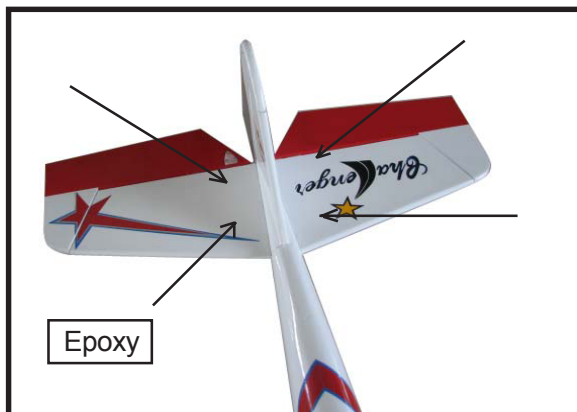

INSTALLING THE AILERON SERVOS.



⚠ *Because the size of servos differ, you may need to adjust the size of the precut opening in the mount. The notch in the sides of the mount allow the servo lead to pass through.*

Using a small weight (*Weighted fuel pick-up works well*) and string, feed the string through the wing as indicated.

Attach the string to the servo lead and carefully thread it through the wing. Once you have string the lead through the wing, remove the string so it can use for the other servo lead. Tape the servo lead to the wing to prevent it from falling back into the wing.

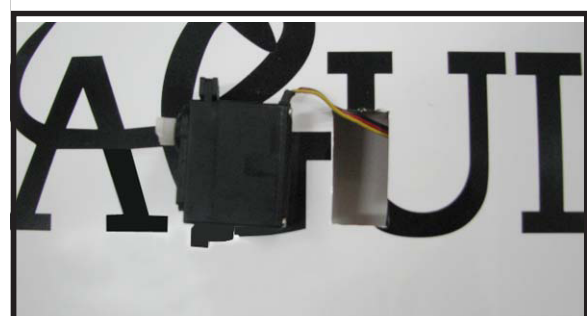
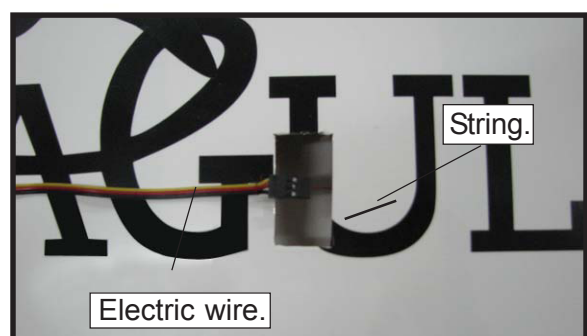

Secure the servos with the screws provided with your radio system.



Repeat the procedure for the other wing.

ELEVATOR - RUDDER PUSHROD INSTALLATION.

□1) Thread one clevis and M2 lock nut on to each elevator control rod. Thread the horns on until they are flush with the ends of the control rods.

□2) Elevator and rudder pushrods assembly follow pictures below.

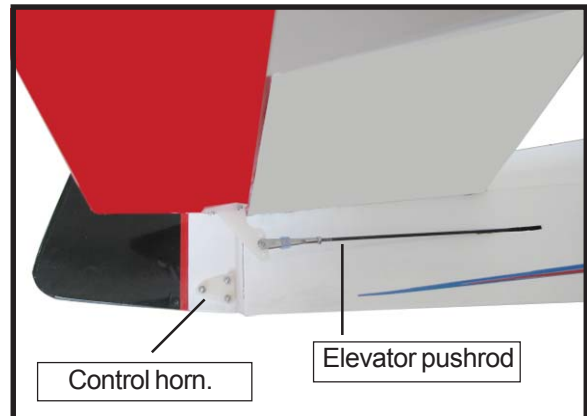
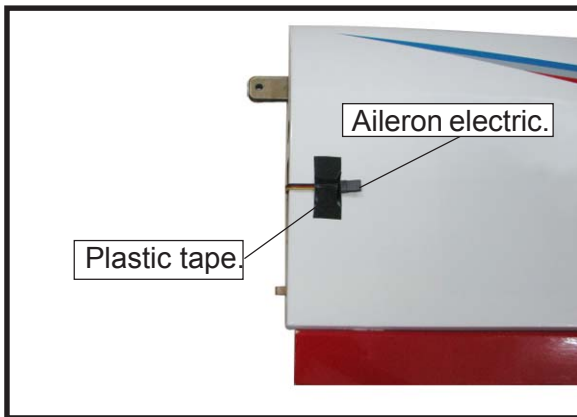
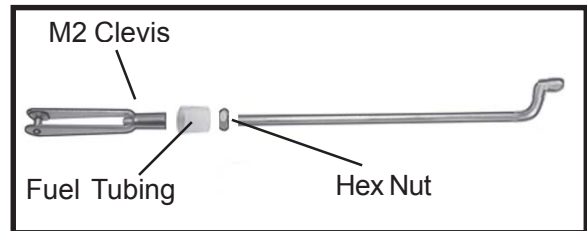
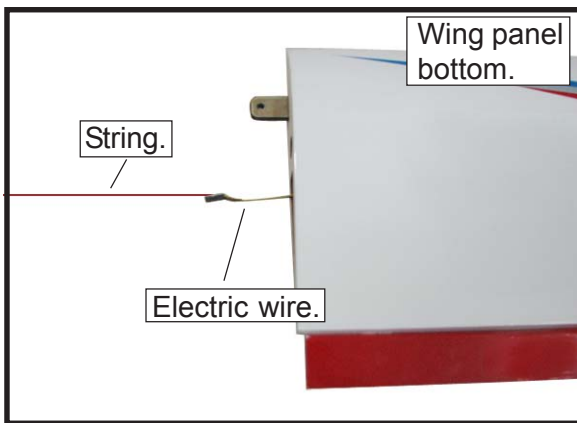

Repeat the procedure for orther wing haft.

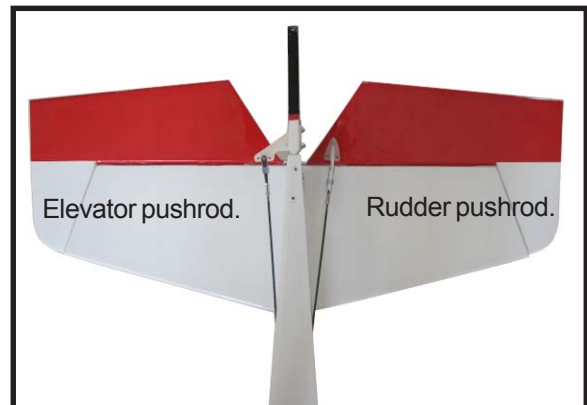
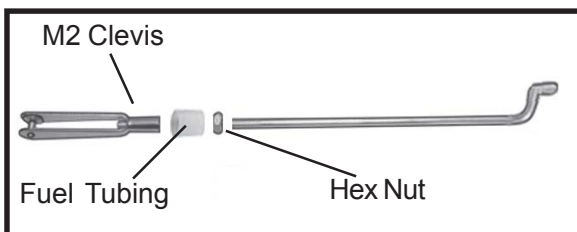

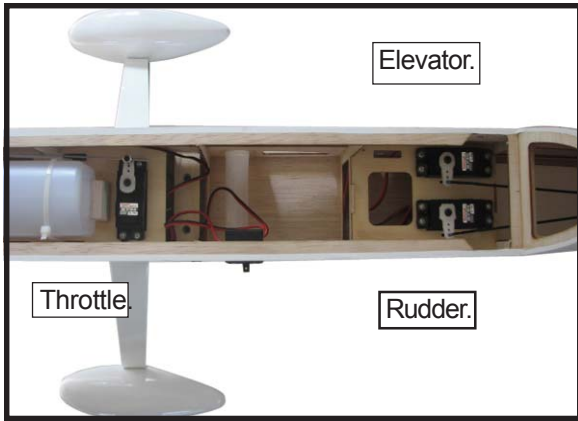

MOUNTING THE CONTROL CLASP.

See pictures below.

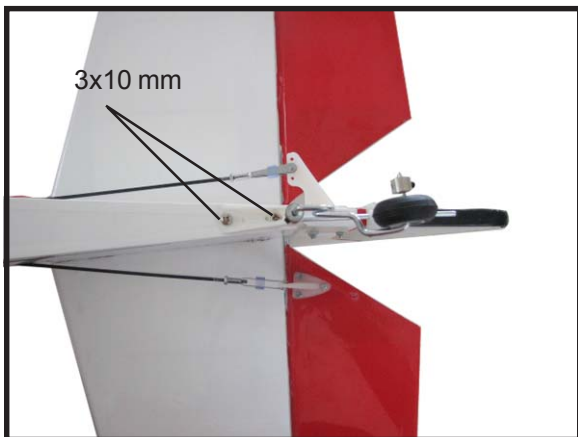
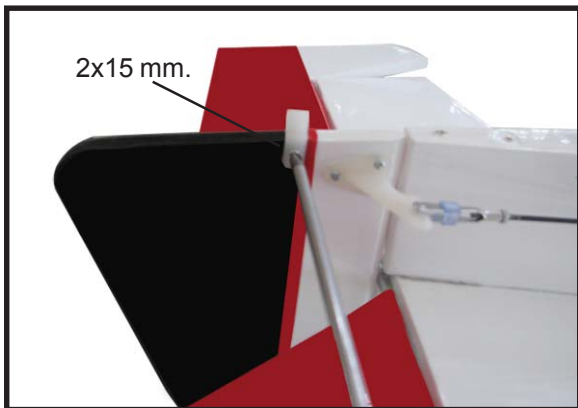
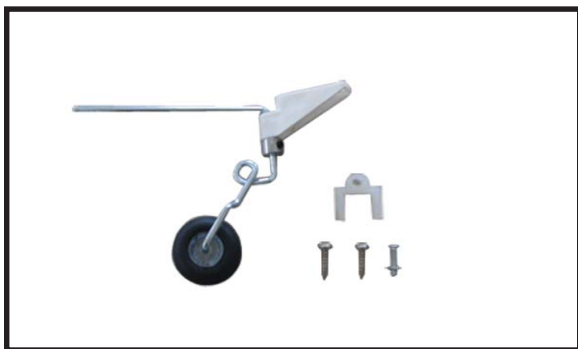

INSTALLING THE BATTERY-RECEIVER.

- 1) Plug the six servo leads and the switch lead into the receiver. Plug the battery pack lead into the switch also.
- 2) Wrap the receiver and battery pack in the protective foam rubber to protect them from vibration.
- 3) Route the antenna in the antenna tube inside the fuselage and secure it to the bottom of fuselage using a plastic tape.

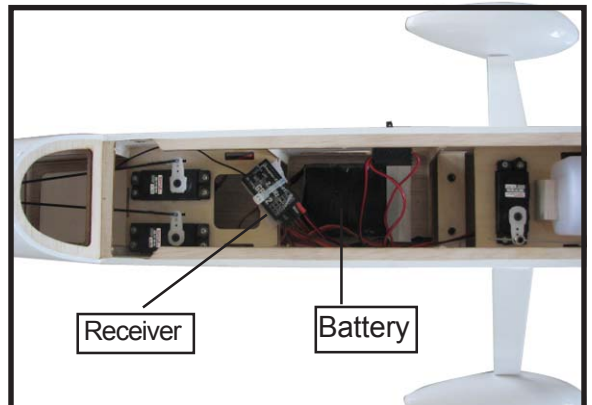

ATTACHMENT WING-FUSELAGE.

Attach the aluminium tube into fuselage.

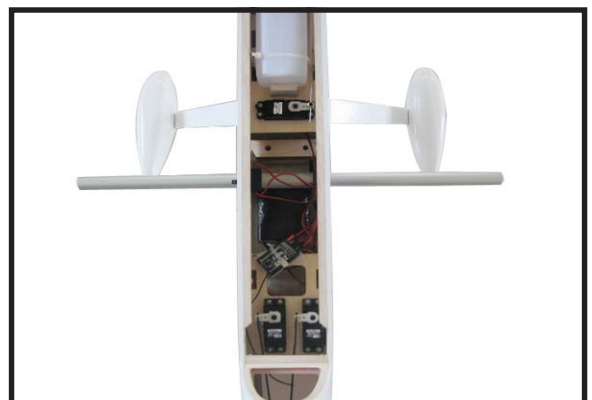

Insert two wing panels as pictures below.

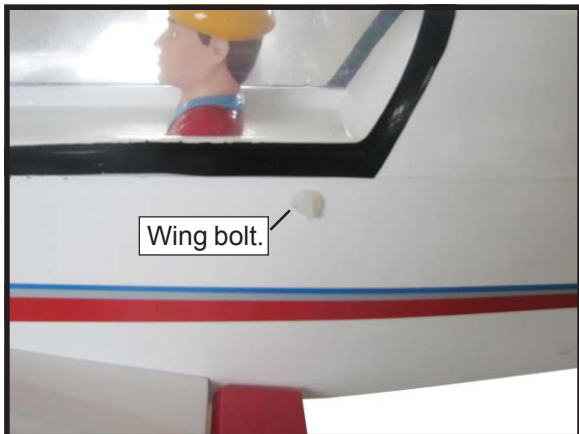
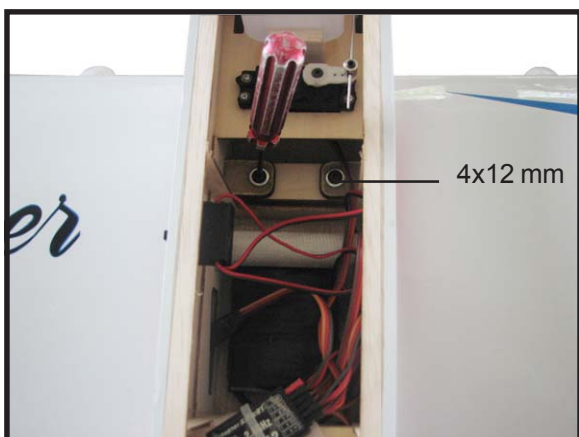
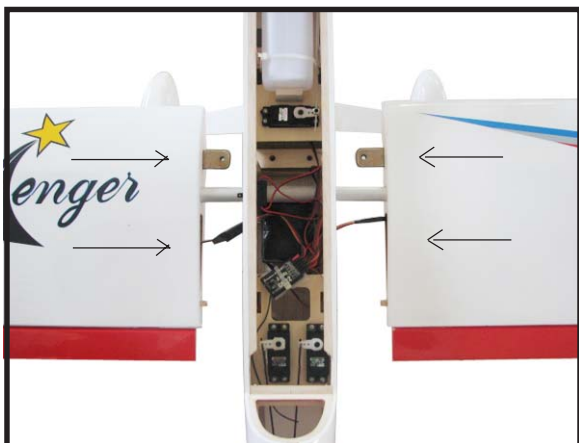

BALANCING.

□1) It is critical that your airplane be balanced correctly. Improper balance will cause your plane to lose control and crash. The center of gravity is located **60mm** back from the leading edge of the wing, measured at wing tip.

□2) Mount the wing to the fuselage. Using a couple of pieces of masking tape, place them on the top side of the wing **60mm** back from the leading edge of the wing at the wing root.

□3) Turn the airplane upside down. Place your fingers on the masking tape and carefully lift the plane

Accurately mark the balance point on the top of the wing on both sides of the fuselage. The balance point is located 60mm back from the leading edge of the wing at the wing root. This is the balance point at which your model should balance for your first flights. Later, you may wish to experiment by shifting the balance up to 10mm forward or back to change the flying characteristics. Moving the balance forward may improve the smoothness and arrow-like tracking but it may then require more speed for take off and make it more difficult to slow down for landing. Moving the balance aft makes the model more agile with a lighter and snappier "feel". In any case, please start at the location we recommend.

With the wing attached to the fuselage, all parts of the model installed (ready to fly), and empty fuel tanks, hold the model at the marked balance point with the stabilizer level.

Lift the model. If the tail drops when you lift, the model is "tail heavy" and you must add weight* to the nose. If the nose drops, it is "nose heavy" and you must add weight * to the tail to balance.

*If possible, first attempt to balance the model by changing the position of the receiver battery and receiver. If you are unable to obtain good balance by doing so, then it will be necessary to add weight to the nose or tail to achieve the proper balance point.

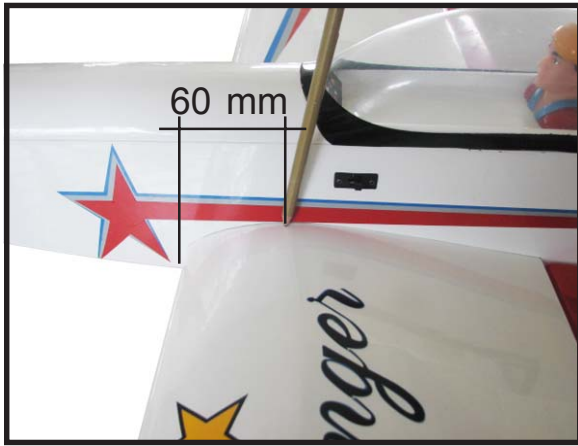

CONTROL THROWS.

Ailerons :		Rudder :	
High Rate :		High Rate :	
Up :	12 mm	Right :	25 mm
Down :	12 mm	Left :	25 mm
Low Rate :		Low Rate :	
Up :	8 mm	Right :	20 mm
Down :	8 mm	Left :	20 mm
Elevator :			
High Rate :			
Up :	20 mm		
Down :	20 mm		
Low Rate :			
Up :	15 mm		
Down :	15 mm		

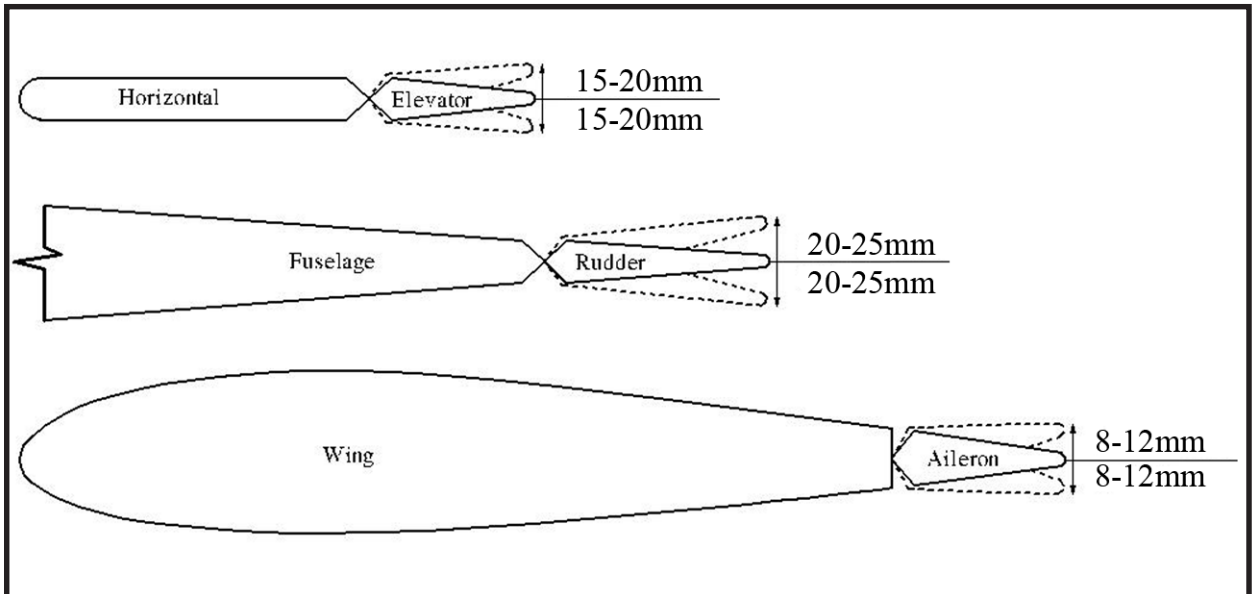

FLIGHT PREPARATION.

- A) Check the operation and direction of the elevator, rudder, ailerons and throttle.
- B) Plug in your radio system per the manufacturer's instructions and turn everything on.
- C) Check the elevator first. Pull back on the elevator stick. The elevator halves should move up. If they do not, flip the servo reversing switch on your transmitter to change the direction.
- D) Check the rudder. Looking from behind the airplane, move the rudder stick to the right. The rudder should move to the right. If it does not, flip the servo reversing switch on your transmitter to change the direction.
- E) Check the throttle. Moving the throttle stick forward should open the carburetor barrel. If it does not, flip the servo reversing switch on your transmitter to change the direction.
- F) From behind the airplane, look at the aileron on the right wing half. Move the aileron stick to the right. The right aileron should move up and the other aileron should move down. If it does not, flip the servo reversing switch on your transmitter to change the direction.

PREFLIGHT CHECK.

- 1) Completely charge your transmitter and receiver batteries before your first day of flying.
- 2) Check every bolt and every glue joint in the **CHALLENGER** to ensure that everything is tight and well bonded.
- 3) Double check the balance of the airplane. Do this with the fuel tank empty.
- 4) Check the control surfaces. All should move in the correct direction and not bind in any way.
- 5) If your radio transmitter is equipped with dual rate switches double check that they are on the low rate setting for your first few flights.
- 6) Check to ensure the control surfaces are moving the proper amount for both low and high rate settings.
- 7) Check the receiver antenna. It should be fully extended and not coiled up inside the fuselage.
- 8) Properly balance the propeller. An out of balance propeller will cause excessive vibration which could lead to engine and/or airframe failure.

**We wish you many safe and enjoyable flights
with your CHALLENGER.**